

Individual Technical Data Sheets

DYNAWELL

Version 1, August 2001

**For the latest information please visit
our web site**

www.dynawell.de

Main Office:

P.O. Box 1261
53822 Troisdorf
Germany
Tel: +49 2241 89 1594
Fax: +49 2241 89 1288
Email: dynawell@dynamit-nobel.com

DW Detonating Cords

PT 250	HNS
PT 250 slim	HNS
PT 165	HMX
PT 185	HMX
PT 185 slim	HMX
T 190	HMX
T 190 slim	HMX
PT 150	RDX
T 150	RDX
Dynacord 16	PETN
Supercord 20	PETN

Inside this issue:

DW Detonators

0015 FD	RDX
0026 FD	HNS
Z 480	RDX
1018	HNS
1019s	HNS
1423	HNS
0015 FDE	RDX
0026 FDE	HNS
1015 E	HMX

DW Boosters

HMX Booster	HMX
HNS Booster long	HNS
HNS Booster short	HNS

DW Misc.

Electronic Igniter	BP
Percussion Initiator	HNS

Technical Data Sheet

NO. TD Z 948
ISSUE: C-2001/08

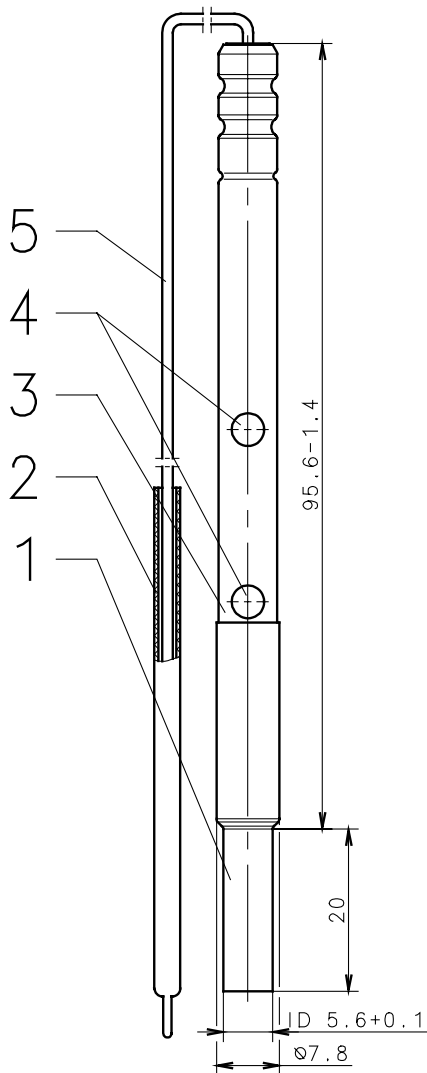

- 1 SLEEVE
- 2 SHUNT
- 3 ALUMINIUM-SHELL
- 4 HOLES
- 5 LEG WIRE

CHANGES POSSIBLE
ALL DIMENSIONS IN mm

INSTANTANEOUS DETONATOR DYNAWELL 0015 FD

APPLICATION:

FLUID DISABLED, TEMPERATURE
RESISTANT DETONATOR FOR OILFIELD USE

TEMPERATURE RESISTANCE:

150 °C / 1 h 302 °F / 1 h

ELECTRICAL PARAMETERS:

RESISTANCE: 50 ± 2 Ω

NO FIRE CURRENT: 0.2 A

ALL FIRE CURRENT: 0.8A

FLUID DESENSITIZATION:

AFTER 2 MINUTES IN WATER

EXPLOSIVES:

RDX 600 mg

9.25 grains

OUTPUT CHARGE

RECOMMENDED WIRE STRIPPER:

IDEAL-STRIPMASTER-SPEZIAL 45-171 WITH
BLADE L-5211

SHELF LIFE:

5 YEARS

AT STORAGE CONDITION:

+ 5 °C TO + 30 °C

+ 41 °F TO + 86 °F

max. 65% HR

GOOD VENTILATION

Kaiserstrasse 1, D-53839 Troisdorf
Germany
Tel.: +49 (0)2241 89 1594
dynawell@dynamit-nobel.com

Dynamit Nobel GmbH
Explosivstoff- und Systemtechnik

Technical Data Sheet

NO. TD Z 967
ISSUE: D-2001/08

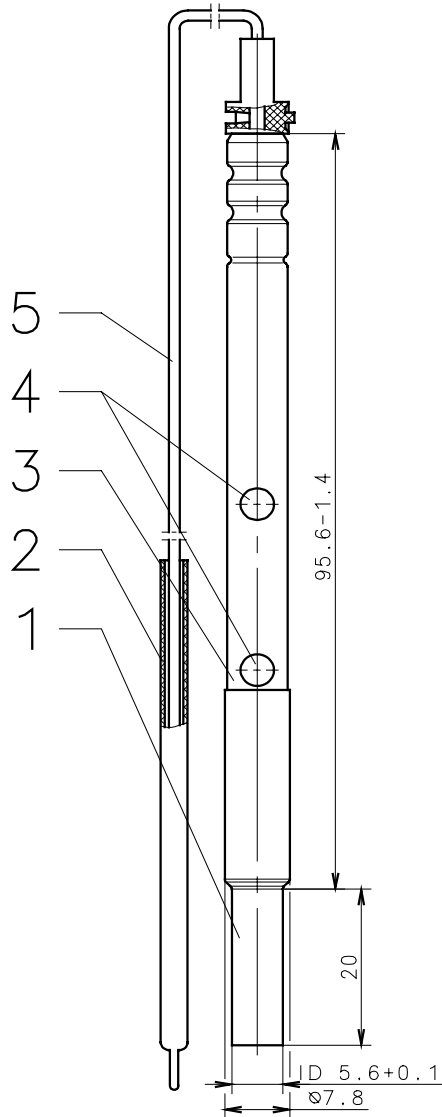

- 1 SLEEVE
- 2 SHUNT
- 3 ALUMINIUM-SHELL
- 4 HOLES
- 5 LEG WIRE

CHANGES POSSIBLE
ALL DIMENSIONS IN mm

INSTANTANEOUS DETONATOR DYNAWELL 0026 FD

APPLICATION:

FLUID DISABLED, TEMPERATURE
RESISTANT DETONATOR FOR OILFIELD USE

TEMPERATURE RESISTANCE:

260 °C / 1 h 500 °F / 1h

ELECTRICAL PARAMETERS:

RESISTANCE: 50 ± 2 Ω

NO FIRE CURRENT: 0.2 A

ALL FIRE CURRENT: 0.8 A

FLUID DESENSITIZATION:

AFTER 2 MINUTES IN WATER

EXPLOSIVES:

HNS 600 mg

9.25 grains

OUTPUT CHARGE

RECOMMENDED WIRE STRIPPER

IDEAL-STRIPMASTER-SPEZIAL 45-171 WITH
BLADE L-5211

SHELF LIFE:

5 YEARS

AT STORAGE CONDITION:

+ 5 °C TO + 30 °C + 41 °F TO + 86 °F

max. 65% HR

GOOD VENTILATION

Technical Data Sheet

NO. TD Z 891
ISSUE: B-2001/08

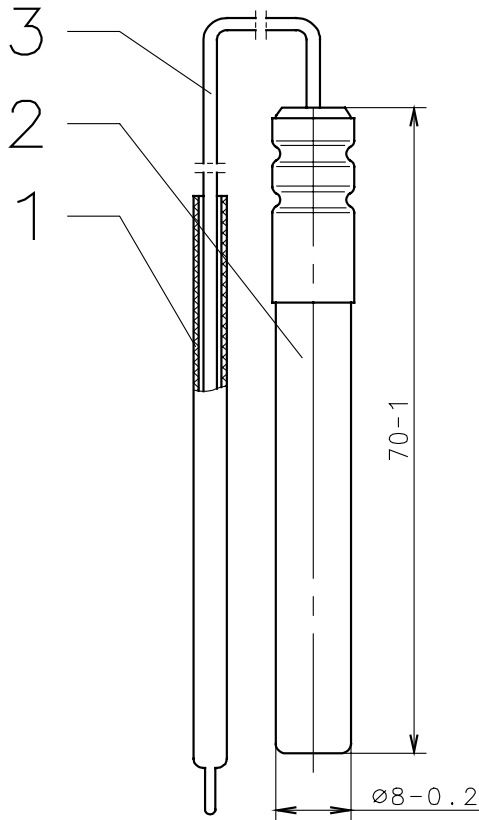

- 1 SHUNT
- 2 COPPER-SHELL
- 3 LEG WIRE

CHANGES POSSIBLE
ALL DIMENSIONS IN mm

INSTANTANEOUS DETONATOR DYNAWELL 1019S

APPLICATION:

TEMPERATURE AND PRESSURE RESISTANT
DETONATOR FOR OILFIELD USE

PRESSURE / TEMPERATURE RESISTANCE:

190 °C / 1.000 bar / 1 h 374 °F / 14.400 psi / 1 h

ELECTRICAL PARAMETERS:

RESISTANCE: 50 ± 2 Ω

NO FIRE CURRENT: 0.2 A

ALL FIRE CURRENT: 0.8 A

EXPLOSIVES:

HNS 205 mg 3.16 grains
OUTPUT CHARGE

RECOMMENDED WIRE STRIPPER

IDEAL-STRIPMASTER-SPEZIAL 45-171 WITH
BLADE L-5211

SHELF LIFE:

5 YEARS

AT STORAGE CONDITION:

+ 5 °C TO + 30 °C + 41 °F TO + 86 °F
max. 65% HR
GOOD VENTILATION

Kaiserstrasse 1, D-53839 Troisdorf
Germany
Tel.: +49 (0)2241 89 1594
dynawell@dynamit-nobel.com

Dynamit Nobel GmbH
Explosivstoff- und Systemtechnik

Technical Data Sheet

NO. TD Z 1473
ISSUE: 2001/08

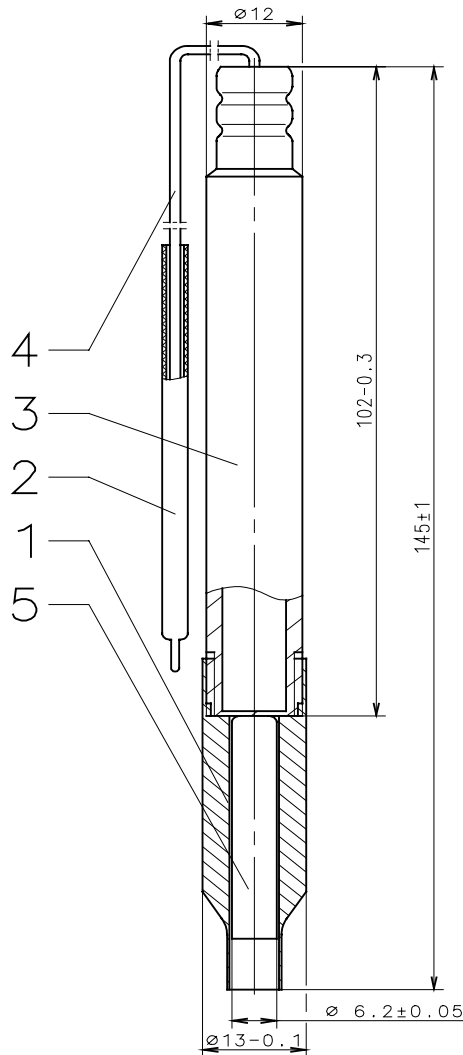

- 1 SLEEVE (CAN BE UNSCREWED)
- 2 SHUNT
- 3 COPPER-SHELL
- 4 LEG WIRE
- 5 HNS BOOSTER

CHANGES POSSIBLE
ALL DIMENSIONS IN mm

INSTANTANEOUS DETONATOR DYNAWELL 1423

APPLICATION:

HIGH TEMPERATURE AND HIGH PRESSURE
RESISTANT DETONATOR FOR OILFIELD USE

PRESSURE / TEMPERATURE RESISTANCE:

230 °C / 1.400 bar / 1 h 446 °F / 21.000 psi / 1 h

IN COMBINATION WITH APPROPRIATE
BOOSTER AND DETONATING CORD

ELECTRICAL PARAMETERS:

RESISTANCE: 50 ± 2 Ω
NO FIRE: 0.2 A (DC-CURRENT)
ALL FIRE: 0.8 A (DC-CURRENT)

EXPLOSIVES:

HNS 950 mg 14.65 grains
OUTPUT CHARGE
TO FIRE THE HNS BOOSTER

RECOMMENDED WIRE STRIPPER:

IDEAL-STRIPMASTER-SPEZIAL 45-171 WITH
BLADE L-5211

SHELF LIFE:

5 YEARS

AT STORAGE CONDITION:

+ 5 °C TO + 30 °C + 9.7 °F TO + 58.2 °F
max. 65% HR
GOOD VENTILATION

Technical Data Sheet

NO. TD Z 983
ISSUE: D-2001/08

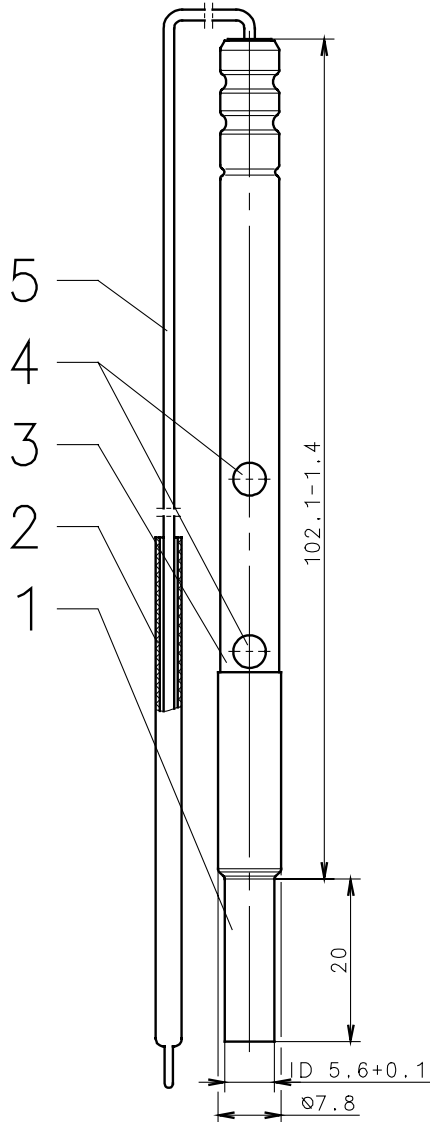

- 1 SLEEVE
- 2 SHUNT
- 3 ALUMINIUM-SHELL
- 4 HOLES
- 5 LEG WIRE

CHANGES POSSIBLE
ALL DIMENSIONS IN mm

INSTANTANEOUS DETONATOR DYNAWELL 0026 FDE

APPLICATION:

RF-SAFE, FLUID DISABLED, TEMPERATURE RESISTANT DETONATOR FOR OILFIELD USE

TEMPERATURE RESISTANCE:

150 °C / 1 h 302 °F / 1 h
260 °C / 1 h 500 °F / 1 h WITH HEAT
INSULATED SPECIAL VACCUM FLASK

ELECTRICAL PARAMETERS:

RESISTANCE: 12.7 kΩ ± 3.2 kΩ

(MEASURING VOLTAGE 12 V)
DIGITAL LOCKED

OPERATION ONLY POSSIBLE WITH THE
SUITABLE DYNAWELL DIGITAL FIRING PANEL

SAFE AGAINST STATIC ELECTRICITY
(2500 PF 30 KV)
SAFE AGAINST HIGH FREQUENCY
(200 MHZ, 200 V/M)
SAFETY TESTED AT 50 V AND 20 A

FLUID DESENSITIZATION:

AFTER 2 MINUTES IN WATER

EXPLOSIVES:

HNS 600 mg 9.25 grains
OUTPUT CHARGE

RECOMMENDED WIRE STRIPPER

IDEAL-STRIPMASTER-SPEZIAL 45-171 WITH
BLADE L-5211

SHELF LIFE:

5 YEARS

AT STORAGE CONDITION:

+ 5 °C TO + 30 °C + 41 °F TO + 86 °F
max. 65% HR
GOOD VENTILATION

Kaiserstrasse 1, D-53839 Troisdorf
Germany
Tel.: +49 (0)2241 89 1594
dynawell@dynamit-nobel.com

Dynamit Nobel GmbH
Explosivstoff- und Systemtechnik

Technical Data Sheet

NO. TD Z 1139
ISSUE: C-2001/08

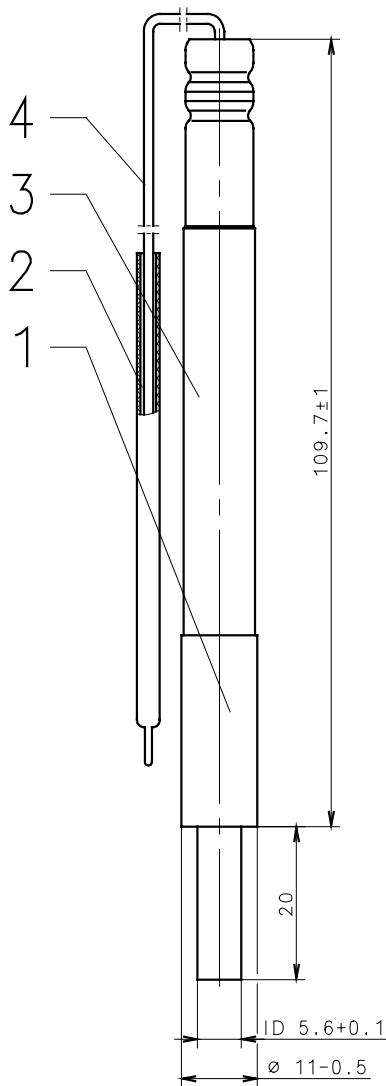

- 1 SLEEVE
- 2 SHUNT
- 3 COPPER SHELL
- 4 LEG WIRE

CHANGES POSSIBLE
ALL DIMENSIONS IN mm

INSTANTANEOUS DETONATOR DYNAWELL 1015E

APPLICATION:

RF-SAFE, TEMPERATURE AND PRESSURE RESISTANT DETONATOR FOR OILFIELD USE

PRESSURE / TEMPERATURE RESISTANCE:

150 °C / 1.000 bar / 1 h 302 °F / 14.400 psi / 1 h

ELECTRICAL PARAMETERS:

RESISTANCE: 12.7 kΩ ± 3.2 kΩ

(MEASURING VOLTAGE 12 V)
DIGITAL LOCKED

OPERATION ONLY POSSIBLE WITH THE SUITABLE DYNAWELL DIGITAL FIRING PANEL

SAFE AGAINST STATIC ELECTRICITY (2500 PF 30 KV)
SAFE AGAINST HIGH FREQUENCY (200 MHZ, 200 V/M)
SAFETY TESTED AT 50 V AND 20 A

EXPLOSIVES:

HMX 1280 mg 19.74 grains
OUTPUT CHARGE

RECOMMENDED WIRE STRIPPER:

IDEAL-STRIPMASTER-SPEZIAL 45-171 WITH BLADE L-5211

SHELF LIFE:

5 YEARS

AT STORAGE CONDITION:

+ 5 °C TO + 30 °C + 41 °F TO + 86 °F
max. 65% HR
GOOD VENTILATION

Technical Data Sheet

NO. TD Z 1289
ISSUE: A-2001/08

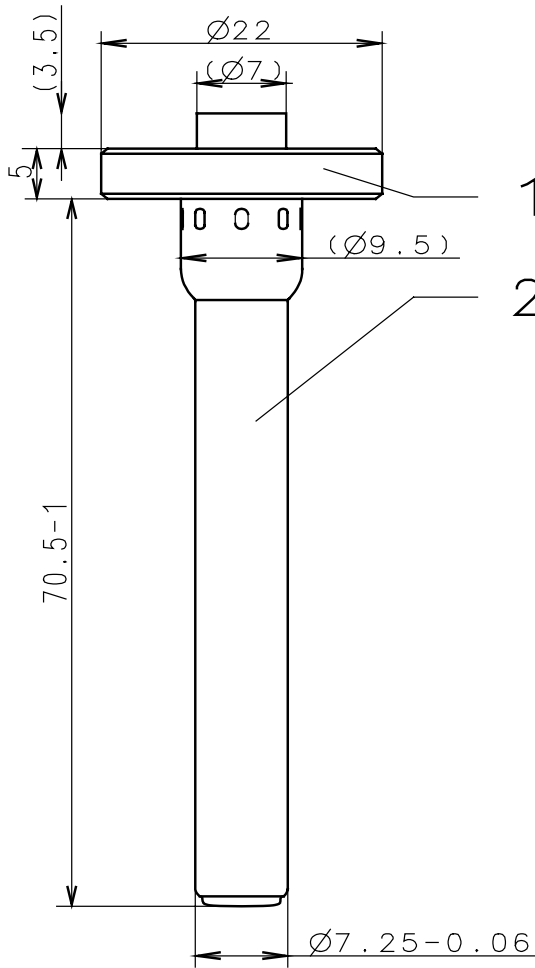

- 1 CONTACT ASSEMBLIES
2 COPPER SHELL

CHANGES POSSIBLE
ALL DIMENSIONS IN mm

ELECTRONIC IGNITER FOR SETTING TOOL (EIST)

APPLICATION:

RF-SAFE, TEMPERATURE RESISTANT
IGNITER FOR OILFIELD USE

TEMPERATURE RESISTANCE:

150 °C / 1h 302 °F / 1h

ELECTRICAL PARAMETERS:

RESISTANCE: 12.7 kΩ ± 3.2 kΩ

(MEASURING VOLTAGE 12 V)
DIGITAL LOCKED

OPERATION ONLY POSSIBLE WITH THE
SUITABLE DYNAWELL DIGITAL FIRING PANEL

SAFE AGAINST STATIC ELECTRICITY
(2500 PF 30 KV)

SAFE AGAINST HIGH FREQUENCY
(200 MHZ, 200 V/M)

SAFETY TESTED AT 50 V AND 20 A

EXPLOSIVES:

BLACK POWDER 700 mg 10.80 grains
OUTPUT CHARGE

SHELF LIFE:

5 YEARS

AT STORAGE CONDITION:

+ 5 °C TO + 30 °C + 41 °F TO + 86 °F
max. 65% HR
GOOD VENTILATION

Kaiserstrasse 1, D-53839 Troisdorf
Germany
Tel.: +49 (0)2241 89 1594
dynawell@dynamit-nobel.com

Dynamit Nobel GmbH
Explosivstoff- und Systemtechnik
www.dynawell.de

Technical Data Sheet

NO. TD Z 908
ISSUE: B-2001/08

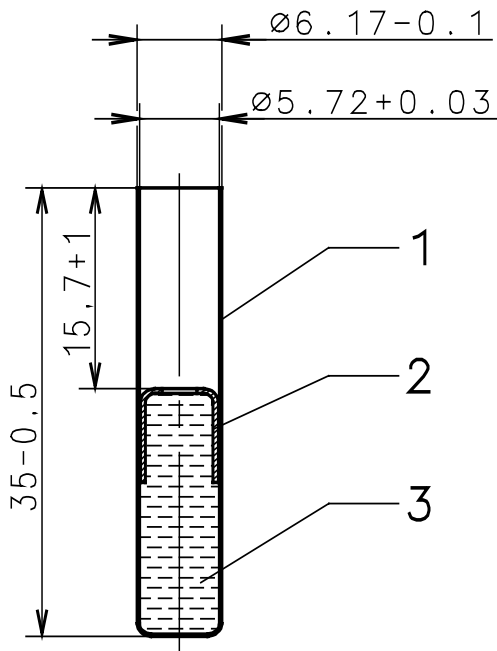

- 1 SLEEVE
- 2 INNER SLEEVE
- 3 CHARGE

CHANGES POSSIBLE
ALL DIMENSIONS IN mm

HMX BOOSTER

APPLICATION:

TEMPERATURE RESISTANT
BI-DIRECTIONAL BOOSTER FOR OILFIELD
USE

SENSITIVITY:

BOOSTER TO BOOSTER TRANSFER AT AIR
GAP OF max. 80 mm (3.15")

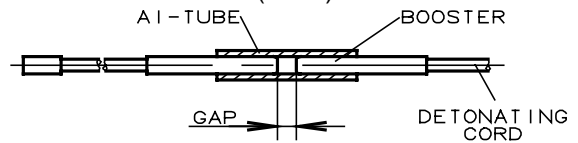

BOOSTER TO DETONATING CORD
TRANSFER AT AIR GAP OF
max. 6 mm (0.236 ")

EXPLOSIVES:

HMX 600 mg 9.25 grains

TEMPERATURE RESISTANCE:

205 °C / 1 h	401 °F / 1 h
180 °C / 24 h	356 °F / 24 h
150 °C / 100 h	302 °F / 100 h

OUTPUT:

DENT IN A STEEL PLATE OF
min. 0.7 mm (0.028 ")

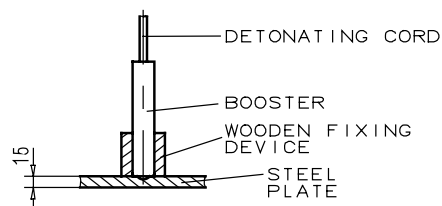

SHELF LIFE:

5 YEARS

AT STORAGE CONDITION:

+ 5 °C TO + 30 °C + 41 °F TO + 86 °F
max. 65% HR
GOOD VENTILATION

Kaiserstrasse 1, D-53839 Troisdorf
Germany
Tel.: +49 (0)2241 89 1594
dynawell@dynamit-nobel.com

Dynamit Nobel GmbH
Explosivstoff- und Systemtechnik
www.dynawell.de

Technical Data Sheet

NO. TD Z 909
ISSUE: B-2001/08

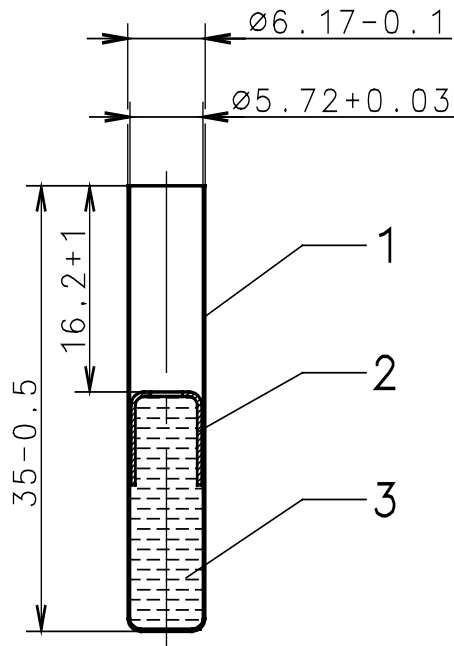

- 1 SLEEVE
- 2 INNER SLEEVE
- 3 CHARGE

CHANGES POSSIBLE
ALL DIMENSIONS IN mm

HNS BOOSTER

APPLICATION:

TEMPERATURE RESISTANT
BI-DIRECTIONAL BOOSTER FOR OILFIELD
USE

SENSITIVITY:

BOOSTER TO BOOSTER TRANSFER AT AIR
GAP OF max. 60 mm (2.36")

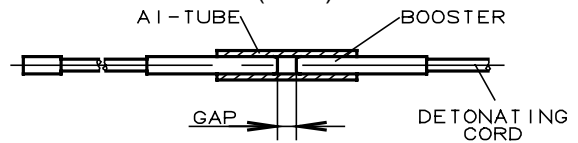

BOOSTER TO DETONATING CORD
TRANSFER AT AIR GAP OF
max. 2 mm (0.08 ")

EXPLOSIVES:

HNS 600 mg 9.25 grains

TEMPERATURE RESISTANCE:

250 °C / 1 h 482 °F / 1 h
230 °C / 100 h 446 °F / 100 h

OUTPUT:

DENT IN A STEEL PLATE OF
min. 0.55 mm (0.021 ")

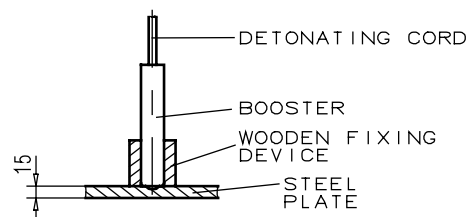

SHELF LIFE:

5 YEARS

AT STORAGE CONDITION:

+ 5 °C TO + 30 °C + 41 °F TO + 86 °F
max. 65% HR
GOOD VENTILATION

Kaiserstrasse 1, D-53839 Troisdorf
Germany
Tel.: +49 (0)2241 89 1594
dynawell@dynamit-nobel.com

Dynamit Nobel GmbH
Explosivstoff- und Systemtechnik
www.dynawell.de

Technical Data Sheet

NO. TD Z 1116
ISSUE: A-2001/08

HNS BOOSTER SHORT

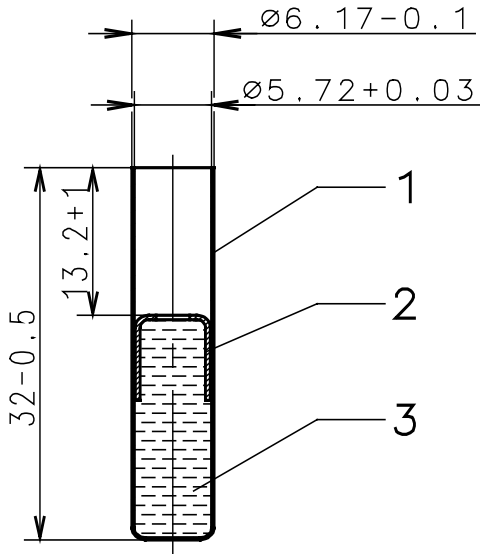

- 1 SLEEVE
- 2 INNER SLEEVE
- 3 CHARGE

CHANGES POSSIBLE
ALL DIMENSIONS IN mm

APPLICATION:

TEMPERATURE RESISTANT
BI-DIRECTIONAL BOOSTER FOR OILFIELD
USE

SENSITIVITY:

BOOSTER TO BOOSTER TRANSFER AT AIR
GAP OF max. 60 mm (2.36")

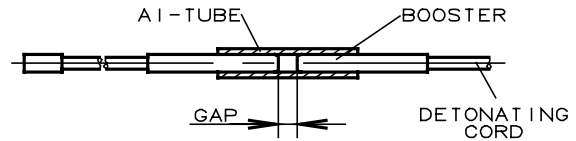

BOOSTER TO DETONATING CORD
TRANSFER AT AIR GAP OF
max. 2 mm (0.08 ")

EXPLOSIVES:

HNS 600 mg 9.25 grains

TEMPERATURE RESISTANCE:

250 °C / 1 h 482 °F / 1 h
230 °C / 100 h 446 °F / 100 h

OUTPUT:

DENT IN A STEEL PLATE OF
min. 0.55 mm (0.021 ")

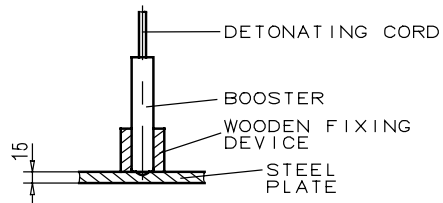

SHELF LIFE:

5 YEARS

AT STORAGE CONDITION:

+ 5 °C TO + 30 °C + 41 °F TO + 86 °F
max. 65% HR
GOOD VENTILATION

Kaiserstrasse 1, D-53839 Troisdorf
Germany
Tel.: +49 (0)2241 89 1594
dynawell@dynamit-nobel.com

Dynamit Nobel GmbH
Explosivstoff- und Systemtechnik
www.dynawell.de

Technical Data Sheet

NO. TD Z 801-23.1
ISSUE: D-2001/08

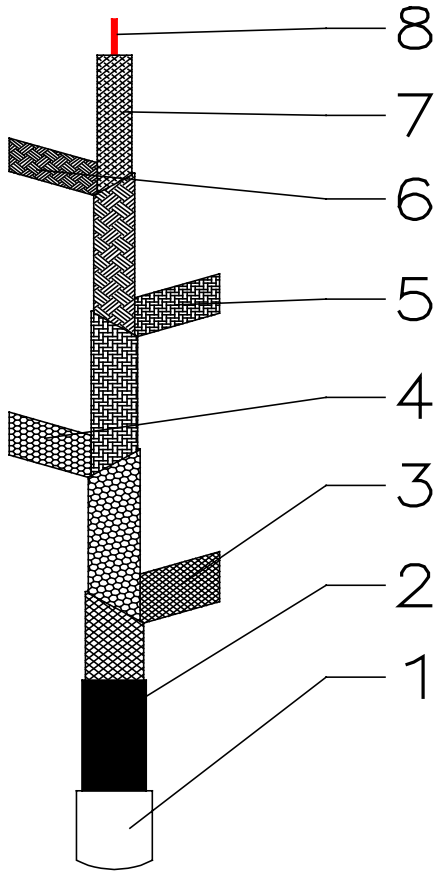

- 1 CAP
- 2 HEAT-RESISTANT SHEATH
- 3 THIRD COVERING WITH THREAD
- 4 SECOND COVERING WITH THREAD
- 5 FIRST COVERING WITH THREAD
- 6 PLASTIC FOIL STRIP
- 7 EXPLOSIVE
- 8 IDENTIFICATION THREAD

CHANGES POSSIBLE

HNS CORD PT 250

APPLICATION:

TEMPERATURE AND PRESSURE RESISTANT
DETONATING CORD FOR OILFIELD USE.
NOT RECOMMENDED FOR USE WITH
EXPOSED GUN SYSTEMS.

EXPLOSIVE CORE LOAD:

HNS 16-18 g/m 75-84 grains/ft

TENSILE STRENGTH:

> 1.000 N > 220 pounds

DETONATION VELOCITY:

6.400 ± 200 m/s 21.000 ± 656 ft/s

TEMPERATURE RESISTANCE:

230 °C / 200 h 446 °F / 200 h
250 °C / 1 h 482 °F / 1 h

FUNCTION TESTED IN LABORATORY

260 °C / 1 h 500 °F / 1 h

TEMPERATURE + PRESSURE RESISTANCE:

200 °C / 1.400 bar / 1 h 392 °F / 20.160 psi / 1 h

OUTSIDE DIAMETER:

5,25 ± 0,25 mm 0,207 ± 0,01 inches

LAP JOINT SENSITIVITY:

NO

MAXIMUM SHRINKAGE:

2 %

JACKET MATERIAL:

FEP - FLUOROPOLYMER

DETONATING CORD COLOR:

BLACK

SHELF LIFE:

5 YEARS

AT STORAGE CONDITION:

+ 5 °C TO + 30 °C + 41 °F TO + 86 °F
max. 65% HR
GOOD VENTILATION

Technical Data Sheet

No. TD Z 801-32.1
Issue: C-2001/08

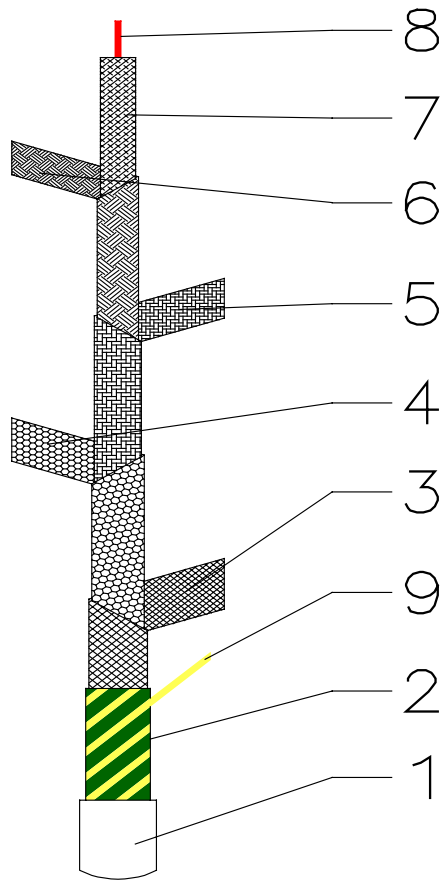

- 1 CAP
- 2 HEAT-RESISTANT SHEATH
- 3 THIRD COVERING WITH THREAD
- 4 SECOND COVERING WITH THREAD
- 5 FIRST COVERING WITH THREAD
- 6 PLASTIC FOIL STRIP
- 7 EXPLOSIVE
- 8 IDENTIFICATION THREAD
- 9 MARKER THREAD

CHANGES POSSIBLE

HNS SLIM PT 250

APPLICATION:

TEMPERATURE AND PRESSURE RESISTANT
DETONATING CORD FOR OILFIELD USE.
NOT RECOMMENDED FOR USE WITH
EXPOSED GUN SYSTEMS.

EXPLOSIVE CORE LOAD:

HNS 12-14 g/m 56-65 grains/ft

TENSILE STRENGTH:

> 1.000 N > 220 pounds

DETONATION VELOCITY:

6.200 ± 200 m/s 20.341 ± 656 ft/s

TEMPERATURE RESISTANCE:

230 °C / 200h 446 °F / 200 h
250 °C / 1 h 482 °F / 1 h

FUNCTION TESTED IN LABORATORY

260 °C / 1 h 500 °F / 1 h

RESISTANCE:

200 °C / 1.400 bar / 1 h 392 °F / 20.160 psi / 1h

OUTSIDE DIAMETER:

4,7 ± 0,2 mm 0,185 ± 0,01 inches

LAP JOINT SENSITIVITY:

NO

MAXIMUM SHRINKAGE:

2 %

JACKET MATERIAL:

FEP - FLUOROPOLYMER

DETONATING CORD COLOR:

DARK GREEN WITH YELLOW MARKER
THREAD

SHELF LIFE:

5 YEARS

AT STORAGE CONDITION:

+ 5 °C TO + 30 °C + 41 °F TO + 86 °F
max. 65% HR
GOOD VENTILATION

Kaiserstrasse 1, D-53839 Troisdorf
Germany
Tel.: +49 (0)2241 89 1594
dynawell@dynamit-nobel.com

Dynamit Nobel GmbH
Explosivstoff- und Systemtechnik

Technical Data Sheet

NO. TD Z 801-20.1
ISSUE: E-2001/08

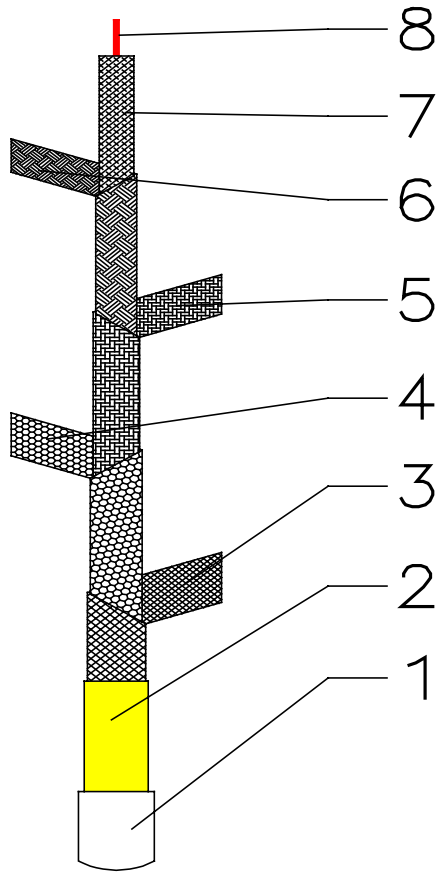

- 1 CAP
- 2 HEAT-RESISTANT SHEATH
- 3 THIRD COVERING WITH THREAD
- 4 SECOND COVERING WITH THREAD
- 5 FIRST COVERING WITH THREAD
- 6 PLASTIC FOIL STRIP
- 7 EXPLOSIVE
- 8 IDENTIFICATION THREAD

CHANGES POSSIBLE

OCTOCORD PT 165

APPLICATION:

TEMPERATURE AND PRESSURE RESISTANT
DETONATING CORD FOR OILFIELD USE

EXPLOSIVE CORE LOAD:

HMX 16-18 g/m 75-84 grains/ft

TENSILE STRENGTH:

> 1.500 N > 330 pounds

DETONATION VELOCITY:

7.900 ± 200 m/s 25.920 ± 656 ft/s

TEMPERATURE RESISTANCE:

146 °C / 209 h 295 °F / 209 h
165 °C / 1 h 330 °F / 1 h

FUNCTION TESTED IN LABORATORY
215 °C / 1 h 420 °F / 1 h

TEMPERATURE + PRESSURE RESISTANCE:

165 °C / 1.000 bar / 1 h 329 °F / 14.400 psi / 1 h

OUTSIDE DIAMETER:

5,2 ± 0,2 mm 0,205 ± 0,008 inches

LAP JOINT SENSITIVITY:

YES

MAXIMUM SHRINKAGE:

2 %

JACKET MATERIAL:

PVDF – POLYVINYLIDENEFLUORIDE

DETONATING CORD COLOR:

YELLOW

SHELF LIFE:

5 YEARS

AT STORAGE CONDITION:

+ 5 °C TO + 30 °C + 41 °F TO + 86 °F
max. 65% HR
GOOD VENTILATION

Kaiserstrasse 1, D-53839 Troisdorf
Germany
Tel.: +49 (0)2241 89 1594
dynawell@dynamit-nobel.com

Dynamit Nobel GmbH
Explosivstoff- und Systemtechnik

Technical Data Sheet

NO. TD Z 801-25.1
ISSUE: C-2001/08

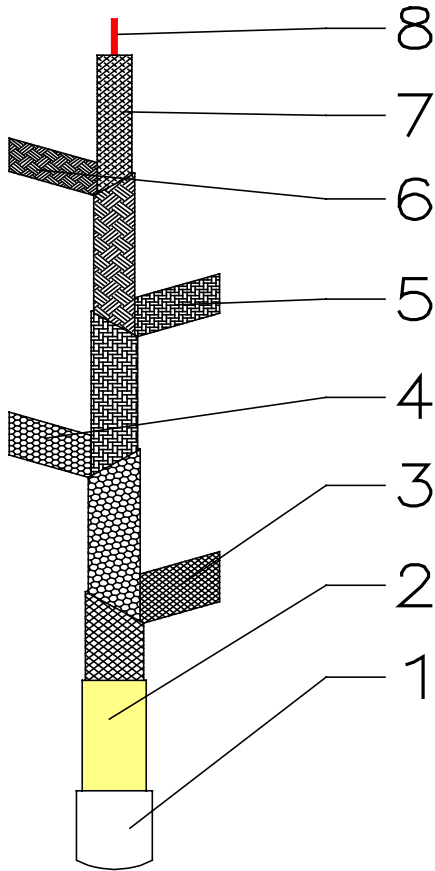

- 1 CAP
- 2 HEAT-RESISTANT SHEATH
- 3 THIRD COVERING WITH THREAD
- 4 SECOND COVERING WITH THREAD
- 5 FIRST COVERING WITH THREAD
- 6 PLASTIC FOIL STRIP
- 7 EXPLOSIVE
- 8 IDENTIFICATION THREAD

CHANGES POSSIBLE

OCTOCORD PT 185

APPLICATION:

TEMPERATURE AND PRESSURE RESISTANT
DETONATING CORD FOR OILFIELD USE

EXPLOSIVE CORE LOAD:

HMX 16-18 g/m 75-84 grains/ft

TENSILE STRENGTH:

> 1.000 N > 220 pounds

DETONATION VELOCITY:

7.900 ± 200 m/s 25.920 ± 656 ft/s

TEMPERATURE RESISTANCE:

205 °C / 1 h 401 °F / 1 h

TEMPERATURE + PRESSURE RESISTANCE:

185 °C / 1.000 bar / 1 h 365 °F / 14.400 psi / 1 h

FUNCTION TESTED IN LABORATORY

190 °C / 1.500 bar / 1 h 374 °F / 2.1600 psi / 1 h

OUTSIDE DIAMETER:

5,25 ± 0,25 mm 0,207 ± 0,01 inches

LAP JOINT SENSITIVITY:

YES

MAXIMUM SHRINKAGE:

2 %

JACKET MATERIAL:

FEP - FLUOROPOLYMER

DETONATING CORD COLOR:

CLEAR / YELLOWISH

SHELF LIFE:

5 YEARS

AT STORAGE CONDITION:

+ 5 °C TO + 30 °C + 41 °F TO + 86 °F
max. 65% HR

GOOD VENTILATION

Kaiserstrasse 1, D-53839 Troisdorf
Germany
Tel.: +49 (0)2241 89 1594
dynawell@dynamit-nobel.com

Dynamit Nobel GmbH
Explosivstoff- und Systemtechnik

Technical Data Sheet

NO. TD Z 801-26.1
ISSUE: C-2001/08

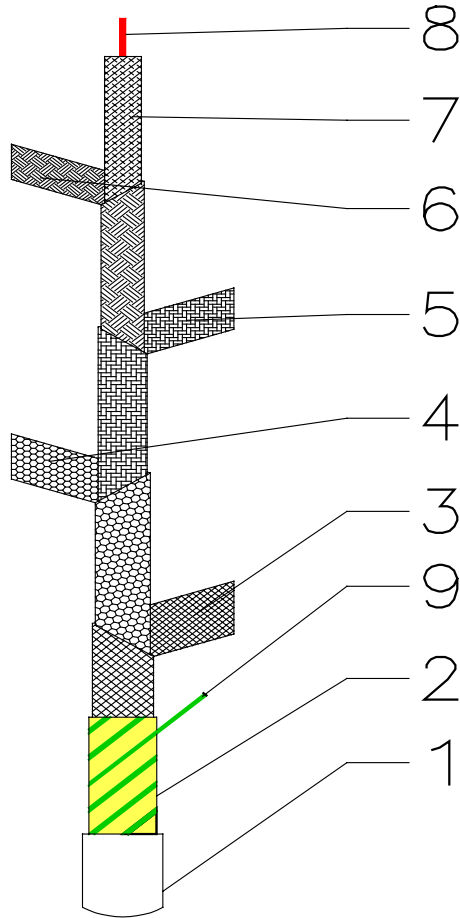

- 1 CAP
- 2 HEAT-RESISTANT SHEATH
- 3 THIRD COVERING WITH THREAD
- 4 SECOND COVERING WITH THREAD
- 5 FIRST COVERING WITH THREAD
- 6 PLASTIC FOIL STRIP
- 7 EXPLOSIVE
- 8 IDENTIFICATION THREAD
- 9 MARKER THREAD

CHANGES POSSIBLE

OCTOSLIM PT 185

APPLICATION:

TEMPERATURE AND PRESSURE RESISTANT
DETONATING CORD FOR OILFIELD USE

EXPLOSIVE CORE LOAD:

HMX 12-14 g/m 56-66 grains/ft

TENSILE STRENGTH:

> 1.000 N > 220 pounds

DETONATION VELOCITY:

7.400 ± 200 m/s 24.280 ± 656 ft/s

TEMPERATURE RESISTANCE:

205 °C / 1 h 401 °F / 1 h

TEMPERATURE + PRESSURE RESISTANCE:

185 °C / 1.000 bar / 1 h 365 °F / 14.400 psi / 1 h

FUNCTION TESTED IN LABORATORY

190 °C / 1.500 bar / 1 h 374 °F / 21.600 psi / 1 h

OUTSIDE DIAMETER:

4,7 ± 0,2 mm 0,185 ± 0,008 inches

LAP JOINT SENSITIVITY:

YES

MAXIMUM SHRINKAGE:

2 %

JACKET MATERIAL:

FEP - FLUOROPOLYMER

DETONATING CORD COLOR:

CLEAR / YELLOWISH
WITH GREEN MARKER THREAD

SHELF LIFE:

5 YEARS

AT STORAGE CONDITION:

+ 5 °C TO + 30 °C + 41 °F TO + 86 °F
max. 65% HR
GOOD VENTILATION

Kaiserstrasse 1, D-53839 Troisdorf
Germany
Tel.: +49 (0)2241 89 1594
dynawell@dynamit-nobel.com

Dynamit Nobel GmbH
Explosivstoff- und Systemtechnik

Technical Data Sheet

NO. TD Z 801-31.1
ISSUE: A-2001/08

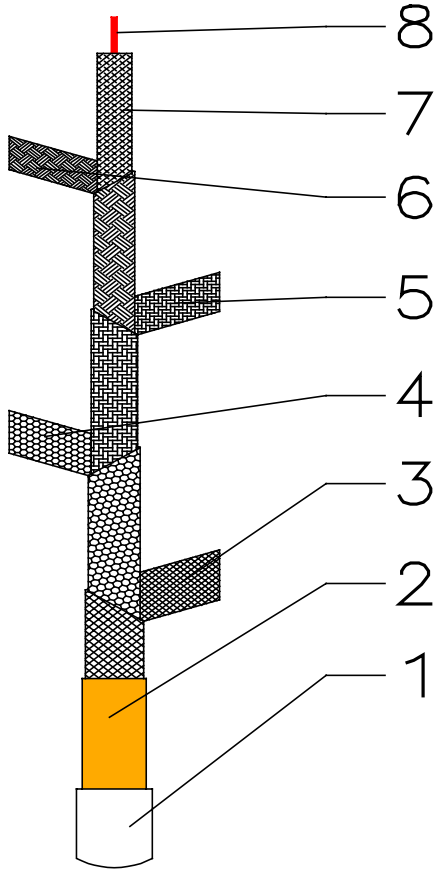

- 1 CAP
- 2 HEAT-RESISTANT SHEATH
- 3 THIRD COVERING WITH THREAD
- 4 SECOND COVERING WITH THREAD
- 5 FIRST COVERING WITH THREAD
- 6 PLASTIC FOIL STRIP
- 7 EXPLOSIVE
- 8 IDENTIFICATION THREAD

CHANGES POSSIBLE

OCTOCORD T 190

APPLICATION:

TEMPERATURE RESISTANT DETONATING CORD FOR OILFIELD USE

EXPLOSIVE CORE LOAD:

HMX 16-18 g/m 75-84 grains/ft

TENSILE STRENGTH:

> 1.000 N > 220 pounds

DETONATION VELOCITY:

7.900 ± 200 m/s 25.920 ± 656 ft/s

TEMPERATURE RESISTANCE:

150 °C / 200 h 302 °F / 200 h
190 °C / 1 h 374 °F / 1 h

FUNCTION TESTED IN LABORATORY
210 °C / 1 h 410 °F / 1 h

OUTSIDE DIAMETER:

5,2 ± 0,2 mm 0,205 ± 0,008 inches

LAP JOINT SENSITIVITY:

YES

MAXIMUM SHRINKAGE:

2 %

JACKET MATERIAL:

PVC - POLYVINYLCHLORIDE

DETONATING CORD COLOR:

DARK YELLOW (ORANGE)

SHELF LIFE:

5 YEARS

AT STORAGE CONDITION:

+ 5 °C TO + 30 °C + 41 °F TO + 86 °F
max. 65% HR
GOOD VENTILATION

Kaiserstrasse 1, D-53839 Troisdorf
Germany
Tel.: +49 (0)2241 89 1594
dynamwell@dynamit-nobel.com

Dynamit Nobel GmbH
Explosivstoff- und Systemtechnik

Technical Data Sheet

No. TD Z 801-33
Issue: B-2001/08

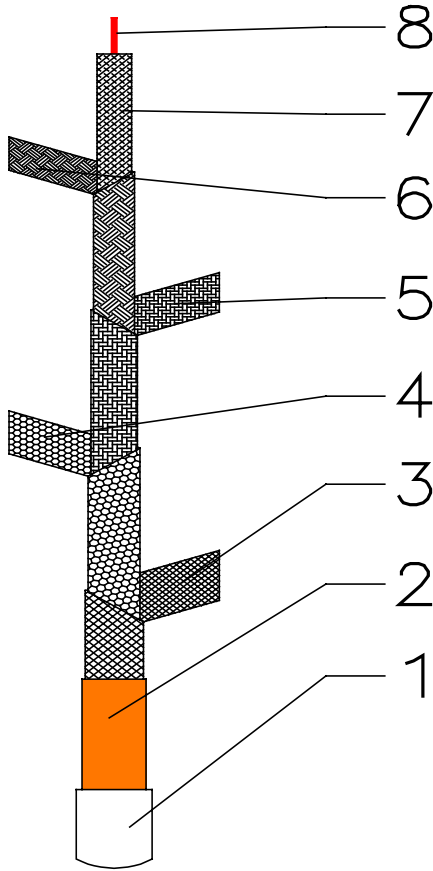

- 1 CAP
- 2 HEAT-RESISTANT SHEATH
- 3 THIRD COVERING WITH THREAD
- 4 SECOND COVERING WITH THREAD
- 5 FIRST COVERING WITH THREAD
- 6 PLASTIC FOIL STRIP
- 7 EXPLOSIVE
- 8 IDENTIFICATION THREAD

CHANGES POSSIBLE

OCTOSLIM T 190

APPLICATION:

TEMPERATURE RESISTANT DETONATING CORD FOR OILFIELD USE

EXPLOSIVE CORE LOAD:

HMX 12-14 g/m 56-65 grains/ft

TENSILE STRENGTH:

> 1.000 N > 220 pounds

DETONATION VELOCITY:

7.600 ± 200 m/s 24.940 ± 656 ft/s

TEMPERATURE RESISTANCE:

150 °C / 200 h 302 °F / 200 h
190 °C / 1 h 374 °F / 1 h

FUNCTION TESTED IN LABORATORY
210 °C / 1 h 410 °F / 1 h

OUTSIDE DIAMETER:

4,7 ± 0,2 mm 0,185 ± 0,008 inches

LAP JOINT SENSITIVITY:

YES

MAXIMUM SHRINKAGE:

2 %

JACKET MATERIAL:

PVC - POLYVINYLCHLORIDE

DETONATING CORD COLOR:

DARK YELLOW (BROWN)

SHELF LIFE:

5 YEARS

AT STORAGE CONDITION:

+ 5 °C TO + 30 °C + 41 °F TO + 86 °F
max. 65% HR
GOOD VENTILATION

Kaiserstrasse 1, D-53839 Troisdorf
Germany
Tel.: +49 (0)2241 89 1594
dynawell@dynamit-nobel.com

Dynamit Nobel GmbH
Explosivstoff- und Systemtechnik

Technical Data Sheet

NO. TD Z 801-22.1
ISSUE: D-2001/08

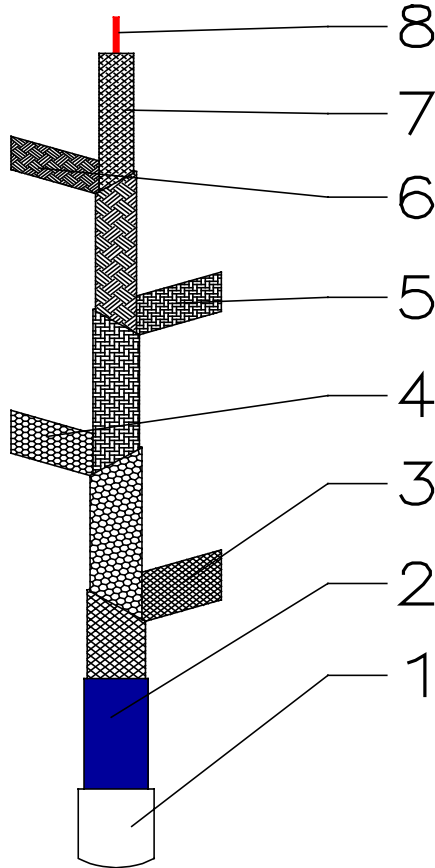

- 1 CAP
- 2 HEAT-RESISTANT SHEATH
- 3 THIRD COVERING WITH THREAD
- 4 SECOND COVERING WITH THREAD
- 5 FIRST COVERING WITH THREAD
- 6 PLASTIC FOIL STRIP
- 7 EXPLOSIVE
- 8 IDENTIFICATION THREAD

CHANGES POSSIBLE

HEXACORD PT 150

APPLICATION:

TEMPERATURE AND PRESSURE RESISTANT
DETONATING CORD FOR OILFIELD USE

EXPLOSIVE CORE LOAD:

RDX 16-18 g/m 75-84 grains/ft

TENSILE STRENGTH:

> 1.000 N > 220 pounds

DETONATION VELOCITY:

7.750 ± 200 m/s 25.430 ± 656 ft/s

TEMPERATURE RESISTANCE:

150 °C / 1 h 302 °F / 1 h

FUNCTION TESTED IN LABORATORY

180 °C / 1h 356 °F / 1 h

TEMPERATURE + PRESSURE RESISTANCE:

150 °C / 1.000 bar / 1 h 302 °F / 14.400 psi / 1 h

FUNCTION TESTED IN LABORATORY

160 °C / 1.100 bar / 1 h 320 °F / 15.800 psi / 1 h

OUTSIDE DIAMETER:

5,2 ± 0,2 mm 0,205 ± 0,008 inches

LAP JOINT SENSITIVITY:

YES

MAXIMUM SHRINKAGE:

2 %

JACKET MATERIAL:

PA - POLYAMIDE

DETONATING CORD COLOR:

DARK BLUE

SHELF LIFE:

5 YEARS

STORAGE CONDITION:

+ 5 °C TO + 30 °C + 41 °F TO + 86 °F

max. 65% HR

GOOD VENTILATION

Kaiserstrasse 1, D-53839 Troisdorf
Germany
Tel.: +49 (0)2241 89 1594
dynawell@dynamit-nobel.com

Dynamit Nobel GmbH
Explosivstoff- und Systemtechnik

Technical Data Sheet

NO. TD Z 801-24.1
ISSUE: D-2001/08

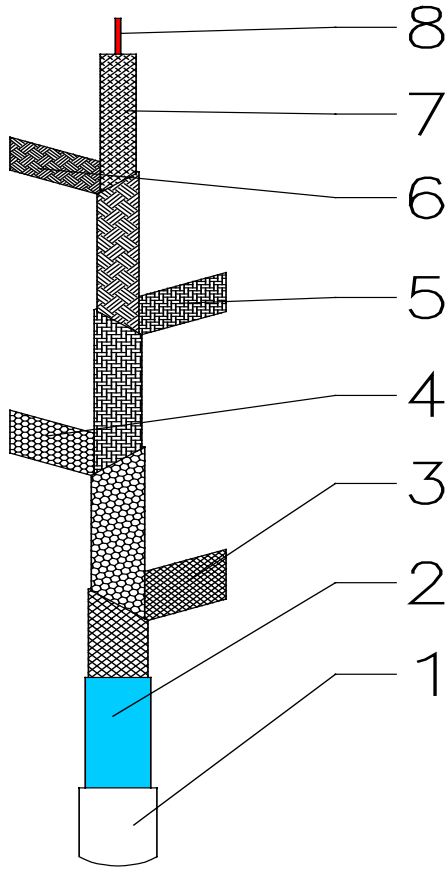

- 1 CAP
- 2 HEAT-RESISTANT SHEATH
- 3 THIRD COVERING WITH THREAD
- 4 SECOND COVERING WITH THREAD
- 5 FIRST COVERING WITH THREAD
- 6 PLASTIC FOIL STRIP
- 7 EXPLOSIVE
- 8 IDENTIFICATION THREAD

CHANGES POSSIBLE

HEXACORD T 150

APPLICATION:

TEMPERATURE RESISTANT DETONATING CORD FOR OILFIELD USE

EXPLOSIVE CORE LOAD:

RDX 16-18 g/m 75-84 grains/ft

TENSILE STRENGTH:

> 800 N > 175 pounds

DETONATION VELOCITY:

7.700 ± 200 m/s 25.263 ± 656 ft/s

TEMPERATURE RESISTANCE:

105 °C / 201 h 221 °F / 201h
160 °C / 24 h 320 °F / 24 h
175 °C / 1 h 347 °F / 1 h

OUTSIDE DIAMETER:

5,2 ± 0,2 mm 0,205 ± 0,008 inches

LAP JOINT SENSITIVITY:

YES

MAXIMUM SHRINKAGE:

2 %

JACKET MATERIAL:

PVC - POLYVINYLCHLORIDE

DETONATING CORD COLOR:

LIGHT BLUE

SHELF LIFE:

5 YEARS

AT STORAGE CONDITION:

+ 5 °C TO + 30 °C + 41 °F TO + 86 °F
max. 65% HR
GOOD VENTILATION

Kaiserstrasse 1, D-53839 Troisdorf
Germany
Tel.: +49 (0)2241 89 1594
dynawell@dynamit-nobel.com

Dynamit Nobel GmbH
Explosivstoff- und Systemtechnik

Technical Data Sheet

No. TD Z 801-30
Issue: C-2001/08

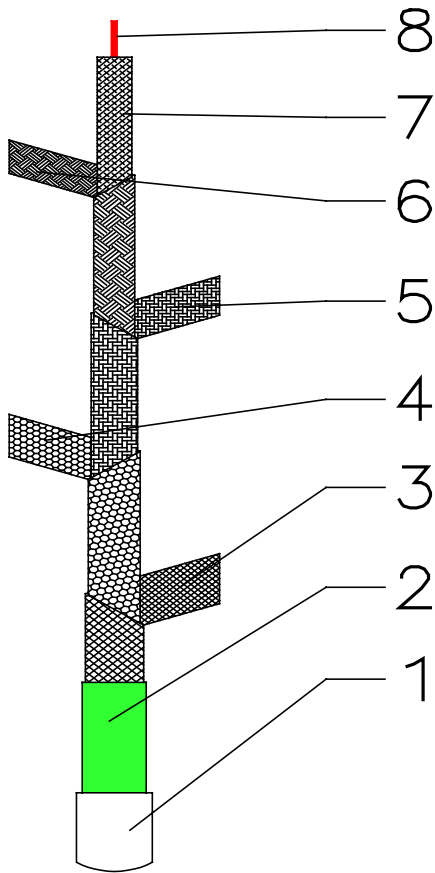

- 1 CAP
- 2 HEAT-RESISTANT SHEATH
- 3 THIRD COVERING WITH THREAD
- 4 SECOND COVERING WITH THREAD
- 5 FIRST COVERING WITH THREAD
- 6 PLASTIC FOIL STRIP
- 7 EXPLOSIVE
- 8 IDENTIFICATION THREAD

CHANGES POSSIBLE

DYNACORD 16

APPLICATION:

TEMPERATURE RESISTANT DETONATING CORD FOR OILFIELD USE

EXPLOSIVE CORE LOAD:

PETN 15-17 g/m 70-79 grains/ft

TENSILE STRENGTH:

> 800 N > 175 pounds

DETONATION VELOCITY:

6.800 ± 400 m/s 22.310 ± 1.300 ft/s

TEMPERATURE RESISTANCE:

100 °C / 1 h 212 °F / 1 h

OUTSIDE DIAMETER:

5,1 ± 0,1 mm 0,201 ± 0,004 inches

LAP JOINT SENSITIVITY:

YES

MAXIMUM SHRINKAGE:

NOT MEASURED

JACKET MATERIAL:

PVC - POLYVINYLCHLORIDE

DETONATING CORD COLOR:

LIGHT GREEN

SHELF LIFE:

5 YEARS

AT STORAGE CONDITION:

+ 5 °C TO + 30 °C + 41 °F TO + 86 °F
max. 65% HR
GOOD VENTILATION

Kaiserstrasse 1, D-53839 Troisdorf
Germany
Tel.: +49 (0)2241 89 1594
dynamit@dynamit-nobel.com

Dynamit Nobel GmbH
Explosivstoff- und Systemtechnik

Technical Data Sheet

NO. TD Z 801-3
ISSUE: A-2001/08

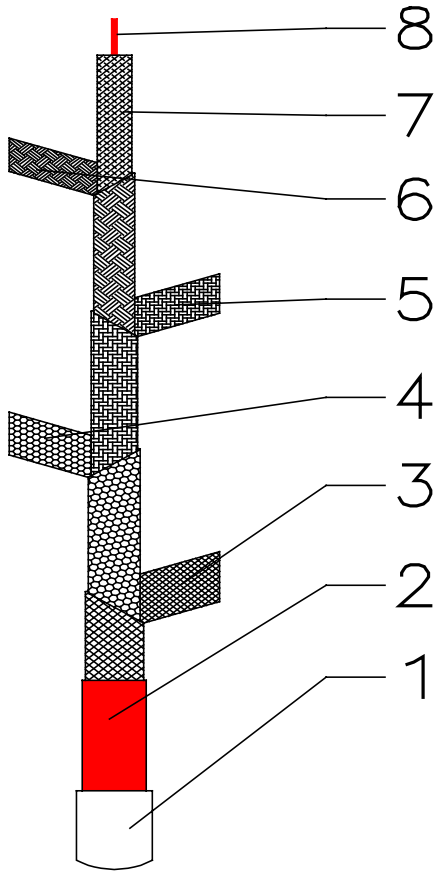

- 1 CAP
- 2 HEAT-RESISTANT SHEATH
- 3 THIRD COVERING WITH THREAD
- 4 SECOND COVERING WITH THREAD
- 5 FIRST COVERING WITH THREAD
- 6 PLASTIC FOIL STRIP
- 7 EXPLOSIVE
- 8 IDENTIFICATION THREAD

CHANGES POSSIBLE

SUPERCORD 20

APPLICATION:

TEMPERATURE RESISTANT DETONATING CORD FOR OILFIELD USE

EXPLOSIVE CORE LOAD:

PETN 19-21 g/m 88-98 grains/ft

TENSILE STRENGTH:

> 800 N > 175 pounds

DETONATION VELOCITY:

6.800 ± 400 m/s 22.310 ± 1.300 ft/s

TEMPERATURE RESISTANCE:

100 °C / 1 h 212 °F / 1 h

OUTSIDE DIAMETER:

6,25 ± 0,25 mm 0,246 ± 0,01 inches

LAP JOINT SENSITIVITY:

YES

MAXIMUM SHRINKAGE:

NOT MEASURED

JACKET MATERIAL:

PVC - POLYVINYLCHLORIDE

DETONATING CORD COLOR:

RED

SHELF LIFE:

5 YEARS

AT STORAGE CONDITION:

+ 5 °C TO + 30 °C + 41 °F TO + 86 °F
max. 65% HR
GOOD VENTILATION